



Orton Ceramic Foundation - 6991 Old 3C Highway,
Westerville, OH 43082-9026
Phone (614) 895-2663, Fax (614) 895-5610
(www.ortonceramic.com)

Autofire® Express
Model N-6 PMC Controller



This button is for selecting a firing program and advancing through the programming steps. After programming is complete, use this button to Start and Stop the firing.



This button is used to change the firing program during programming and to change the display values for specific program settings. During a firing, use this button for special firing options (including Skip Step).



This button is used to change the display values for specific program settings. It is also used to activate the Program Review feature.



When using the Increase and Decrease buttons to change number settings, the values will change more rapidly if the button is held in.

Status Indicator Lights

3 lights are located to the right of the display.

- Program lit during controller programming
- Review lit during Program Review.
- Run lit (blinks) during an active firing.

Audible Alarm

The controller is equipped with a small buzzer that will sound during button presses and at the successful completion of a firing for 30 seconds. The alarm will also sound to notify you of diagnostic alarms that may occur during a firing. To silence an active buzzer, Press any button.

Temperature display preference

All temperature displays on the controller can be viewed as °F (Fahrenheit) or °C (Celsius). The temperature display preference is set by positioning a small circuit board jumper on the back side of the controller that is labeled C/F. The C/F jumper has 2 pin positions, when installed on the 2 corresponding circuit board pins the controller will display all temperatures as °F (Fahrenheit). When no jumper is installed on the 2 circuit board pins the controller will display all temperatures as °C (Celsius). To determine if your controller is set for °F or °C without viewing the jumper position, the small decimal point light in the bottom right-hand corner of the display panel indicates °F or °C. If this decimal point light is lit, the controller is set for °C.

The C/F jumper position is shown on the wiring diagram included in this manual.

Temperature Measurement

The controller monitors and controls temperature from a single Type K thermocouple sensor. Thermocouple probes extend into the firing chamber to measure the temperature. Use caution to avoid damage to the system thermocouple. If the probe is damaged, the controller may not function properly.

Temperature Control

The controller heats the firing chamber by turning relays on and off at the appropriate rate to maintain the program schedule. It is normal to hear the clicking noises associated with turning relays on and off throughout the firing.

Firing Options

The Model N-6 controller allows the operator to use either a predetermined firing schedule for PMC or an operator defined User Program.

PMC Programs

The PMC programs are 5 preset firing schedules for PMC. The various heating steps are preprogrammed for easy selection. You can fire to a preset PMC schedule by simply selecting the PMC Program along with an adjustable target temperature and adjustable Hold time.

The 5 programs are;

PMC Standard Displayed as **Stnd**

This program heats as fast as possible to 1650°F(899°C) and holds this temperature for 2 hours with the option of changing the target temperature and hold time.

PMC+ Fast Displayed as **P F**

This program heats as fast as possible to 1650°F(899°C) and holds this temperature for 10 minutes with the option of changing the target temperature and hold time.

PMC3 Fast Displayed as **P3 F**

This program heats as fast as possible to 1290°F(699°C) and holds this temperature for 10 minutes with the option of changing the target temperature and hold time.

PMC3 Slow Displayed as **P3 S**

This program heats at 1500°F(833°C)/hour to 1110°F(599°C) and holds this temperature for 45 minutes with the option of changing the target temperature and hold time.

PMC Gold Slow Displayed as **G22S**

This program heats at 1500°F(833°C)/hour to 1290°F(699°C) and holds this temperature for 90 minutes with the option of changing the target temperature and hold time.

PMC Target Temperature

If you select a PMC program, you will be given the option of changing the heating target temperature. This allows for correction of over-fired or under-fired ware.

During programming the display prompt for the Temperature setting is **°F 1** or **°C 1** depending on the temperature display preference.

PMC Hold

If you select a PMC program, you will be given the option of changing the final temperature Hold Time. Hold time occurs at the end of firing program before completing the firing cycle.

Hold Time is entered in Hours & Minutes format. The middle decimal point light on the controller display is used to separate Hours from Minutes. For Example, A 1 hour hold time should be set like [01.00], while a 1 hour and 30 minute hold time would be [01.30]. If no hold time is desired, the setting should be [00.00]

The value range available for setting Hold time is 00.00 to 99.58.

During a firing, the hold time begins as soon as the temperature reaches the final temperature. As the hold time progresses, the controller display will count-down the remaining time until the hold time has expired.

During programming the display prompt for the Hold is **Hld1**

For Step-by-Step PMC instruction; see the programming example on page 13

User Program

You can store/save 1 custom (User) firing schedule in the controller memory. The program can be up to 8 Steps long. During programming the display prompt for the User Program is **USER**.

Understanding the User Program

Orton controllers require 3 variables for each heating or cooling step of a firing schedule. These variables are;

1. Heating or cooling rate (Speed)
2. Heating or cooling temperature
3. Hold time (Soak) at heating or cooling temperature.

A complete firing schedule can be multiple heating and/or cooling steps. However, for many applications a single step is all that is required. The maximum number of program steps is limited to 8.

Programming Heating and Cooling Rate

Each step of a firing program must have a programmed Rate of temperature increase or decrease. This is the speed of the heat-up or cool-down. These rate values are selected as Degrees per Hour. 'Degrees per hour' rate can be determined by dividing the total amount of temperature change by the number of hours required to achieve the temperature change. For Example, If you want to heat the kiln to 900°F from room temperature (72°F) in 2 hours time. The heating rate would be 414 Degrees/hour. [900-72 = 828, 828/2 = 414]

During programming the display prompts for all Rate settings is

rA followed by the step number like rA 1, rA 2, rA 3 and so on.

The values available for setting Rate are 0-1798°F/hour or 0-998°C/hour. If it's desired to heat or cool as fast as possible, an alternative setting is available at the beginning or end of the temperature range. This setting appears as FULL on the controller display.

Entering Zero for a heating or cooling rate

The controller determines where your firing program ends by the rA value. If zero is set for any Rate, this tells the controller that there are no more steps to your firing schedule. If additional steps had previously been saved in the active program, all steps after the zero entry will be erased. This feature can also be used to erase an entire firing program by setting the first rA 1 value to zero.

Programming Heating or Cooling Temperatures

Each step of a firing program must have a programmed heating or cooling temperature. The controller must have at least one heating step to accept the firing program as valid (an invalid program results in a bAdP display alarm). A heating step is simply any step with a temperature setting that is above the current display temperature. Cooling steps are automatically determined by the temperature value. If a heating or cooling temperature value is programmed to a lower setting than the previous heating or cooling temperature, it will be a cooling step.

During programming the display prompts for all Heating or Cooling Temperature settings is °F (or °C) followed by the step number like °F 1, °F 2, °F 3 and so on.

The temperature range available for setting heating or cooling temperatures are 32-2400°F or 0-1316°C. If the controller does not allow you to program temperatures up to 2400°F/1316°C, it has been factory set by the supplier to a lower safety temperature. This is often necessary to limit the controller to the maximum operating temperature of the system.

Programming Hold Time

Each step of a firing program can have an optional Hold time. Hold time is the amount of time you want to stay at the previously determined heating or cooling temperature. Hold time is also referred to as Soak or Dwell time.

Hold Time is entered in Hours & Minutes format. The middle decimal point light on the controller display is used to separate Hours from Minutes. For Example, A 1 hour hold time should be set like [01.00], while a 1 hour and 30 minute hold time would be [01.30]. If no hold time is desired, the setting should be [00.00]

A special Hold time is available for indefinite Hold periods. If it is desired to hold the program temperature until someone manually stops the firing or manually advances the program, a hold time of [99.59] represents indefinite Hold.

5

The value range available for setting Hold time is 00.00 to 99.58.

During a firing, the hold time begins as soon as the temperature reaches the heating or cooling temperature. As the hold time progresses, the controller display will count-down the remaining time until the hold time has expired.

During programming the display prompts for all Hold settings is HLd followed by the step number like HLd1, HLd2, HLd3 and so on.

Other Programming Notes

After a firing program is set in the controller, the values will not change or be lost when the controller is turned off.

It is not possible to back-up in the programming mode. If a mistake is made while programming a previous step, you must start over from the ldLE mode to make corrections.

If no buttons are pressed for 1 full minute during programming, the controller will automatically exit the program mode and return to the ldLE display. During a firing, if the options menu is activated for programming, the controller will return to the active display if no buttons are pressed for 1 full minute.

Delay Start Option

Prior to the active start of any firing, the controller display will show a Start prompt of Strt. This appears after the firing program selection and programming. If a delay start time is desired, press the Decrease/Review button to activate a delay start prompt. The display will show dELA alternating with the adjustable delay time in Hours & Minutes format. Use the Increase/Decrease buttons to set the Delay time and then press the Program button when you are ready to start the delay period.

Delay time counts-down on the controller display before the actual start of the firing. When the delay time expires, the actual firing program begins automatically. The Delay time has a setting range of 00.00 (no delay) to 99.59 (99 hours: 59Minutes)

An active delay time can be canceled by pressing the Program/Start button any time during the delay count-down to start the actual firing.

Thermocouple Offset Option

Thermocouple Offset allows you to correct the temperature display a few degrees in a positive or negative direction. This can improve the controller accuracy if the thermocouple probe is aged or if the firing results appear to be slightly under or over fired. This offset allows you to make minor adjustments to the firing temperatures without changing the programmed heating or cooling temperatures.

Prior to the active start of any firing, the controller display will show a Start prompt of Strt. This appears after the firing program selection and programming. If a thermocouple offset is desired, press the

6

Increase/Skip button to activate a thermocouple offset prompt. The display will show tCOS alternating with the adjustable offset value. Use the Increase/Decrease buttons to set the Offset and then press the Program button when you are ready to return to the Strt prompt.

Thermocouple offset (tCOS) has a limited offset range of +/-20°F (+/-11°C). A positive correction will increase the controller display temperature by the amount selected. This will make the firing temperatures lower. A negative correction will decrease the controller display temperature by the amount selected, making the firing temperatures higher.

Program Review

Any time during an active firing, the Program Review feature can be activated to show you the complete firing schedule on the controller display. Press the Decrease/Review button to activate the Program Review. Each segment of your firing schedule will scroll automatically on the display for a few seconds each. To cancel the Review in process, simply press any button.

Program Review can also be activated when the controller is ldLE or during program selection. After this type of Program Review, the controller advances directly to the Start prompt. The Review can be used to bypass making any changes to the current firing schedule.

Options Menu

During an active firing, the Increase/Skip button will activate an options menu and scroll through the available options with each button press. These options allow you to make adjustments to the firing program without stopping the firing. The available options follow.

Skip Step

During an active heating, cooling or hold time, it is possible to skip ahead to the next User Program step. Press the Increase/Skip button to display the Skip Step prompt SSiP. Then Press the Program button to display the current ramp or hold segment. Press the Program button again to initiate the Skip and the controller display returns to the normal firing mode. If the Decrease/Review button is pressed, the Skip function is canceled and the controller display returns to the normal firing mode.

The Skip function can be used to end a Hold time early or to skip from any heating/cooling step to the next heating/cooling step. The Skip function does nothing during the final program step. To end a final program step, simply press Stop.

Add Hold Time

During an active heating, cooling or hold time, it is possible to add more Hold time to the current User Program step or the PMC program. Press the Increase/Skip button until the Hold Time prompt HLdt is displayed. Then Press the Program button to display the current hold time. Press the Increase/Skip button to add 5 minute increments to the original Hold time. Then Press Program button to return to the normal

7

firing mode. If the Decrease/Review button is pressed while the HLdt prompt is displayed, the controller display returns to the normal firing mode.

Change Heating/Cooling Temperature

During an active heating, cooling or hold time, it is possible to change the heating or cooling temperature of the current User Program step or the PMC program. Press the Increase/Skip button until the Change Temperature prompt CHGt is displayed. Then Press the Program button to display the current temperature setting. Adjust the temperature setting with the Increase or Decrease buttons. Then Press Program button to return to the normal firing mode. If the Decrease/Review button is pressed while the CHGt prompt is displayed, the controller display returns to the normal firing mode.

Threshold Alarm

During the firing, it is possible to set an audible alarm and display alarm for when the actual temperature reaches a specified value. The buzzer will sound and the display will show the alarm code ALAr.

To set the alarm, Press Increase/Skip button during the active firing until the alarm prompt ALAr is displayed. Then Press the Program button to display the current alarm temperature setting. Adjust the temperature setting with the Increase or Decrease buttons. Then Press Program button to return to the normal firing mode. If the Decrease/Review button is pressed while the ALAr prompt is displayed, the controller display returns to the normal firing mode.

The alarm is disabled (turned off) when the alarm value is set to 32°F (0°C). The alarm value can be reset or changed many times during a single firing. To silence an active alarm, simply press any button. The maximum programmable value for the alarm is 2400°F (1316°C). If the controller does not allow you to program alarm temperatures up to 2400°F/1316°C, it has been factory set by the supplier to a lower safety temperature. This is often necessary to limit the controller to the maximum operating temperature of the system.

8

Flow Diagram for Options Menu

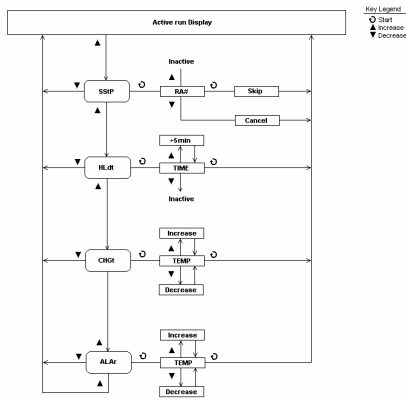

Power Fail Recovery

A firing will resume after a power interruption if certain conditions are met.

1. The controller was not performing a cooling step and the cooling temperature was not exceeded. If so, the display will show the alarm code **PF 1** and terminate the firing.
2. When power is restored the actual temperature must be above 212°F (100°C). If not, the display will show the alarm code **PF 2** and terminate the firing.
3. When power is restored, the temperature drop during the power interruption must be less than 72°F (40°C). If not, the display will show the alarm code **PF 3** and terminate the firing.

Status Display Codes

Below is a list of normal display codes which indicate the controller mode of operation.

IdLE - This is ready mode; No firing in process. This message will alternate with the temperature display and/or any alarm messages that may occur.

dELA - This is the delay start mode. This message will alternate with the delay time count-down if programmed.
Strt - This is a final prompt before starting a new firing. The Delay start and thermocouple offset features are accessed from this prompt.

-On- - This is a short (5 second) display that indicates a new firing has been started.

STOP - This is an Abort message; the firing was stopped early. This message will alternate with the temperature display and/or any alarm messages that may occur.

CPLt - This is a firing complete message; the firing ended successfully. This message will alternate with the temperature display and the total firing time from start to finish.

N-6 - This is a short (5 second) display of the Model number which appears every time the controller is turned on.

Alarm Display Codes

In addition to Power failure alarms, these messages may be displayed if the controller detects a problem during the firing.

tC - This alarm indicates that the thermocouple sensor is no longer detected. The controller can not operate without a thermocouple signal. In most cases, the thermocouple has failed and will need replacement, or the electrical connections for the thermocouple may be loose or damaged. Check the wiring for the thermocouple and the physical condition of the probe inside the firing chamber.

tCr - This alarm indicates that the thermocouple sensor is detected but the signal is reversed. The firing was terminated. The thermocouple signal is a low voltage direct current with a +/- polarity. The controller will sense that the temperature is traveling backwards from what is expected. In most cases, the thermocouple needs reconnected properly. Check the wiring for the thermocouple.

FAIL - This alarm indicates that the thermocouple sensor is no longer detected. The signal was lost during an active firing and the firing was terminated. The controller can not operate without a thermocouple signal. In most cases, the thermocouple has failed and will need replacement, or the electrical connections for the thermocouple may be loose or damaged. Check the wiring for the thermocouple and the physical condition of the probe inside the firing chamber.

FTL - This alarm indicates that the firing was taking too much time to complete and the firing was terminated. The controller monitors the deviation from the desired firing schedule as compared with the actual firing results. There are 2 conditions for the FTL alarm.

1. The heating or cooling rate has slowed to less than 27°F (15°C) per Hour

2. The current program step has lasted 2 hours longer than anticipated.

In most cases, the FTL alarm occurs during heating if the heating rate is set to a fast speed that cannot be maintained by the system. If the heating rate is within the systems capability, a component failure has probably occurred with the heating elements or the control relays.

During cool-down, a well insulated system will have cooling limitation and rapid cooling rates may set off this alarm if the cooling speed cannot be maintained. Increasing the final cool-down temperature or slowing the cooling rate can avoid this alarm.

tCL - This alarm indicates that the thermocouple signal is not responding to the demand for more system power during heat-up. There are 2 conditions for the tCL alarm.

1. The heating or cooling rate has slowed to less than 9°F (5°C) per Hour
2. The actual kiln temperature is lagging behind the desired temperature by more than 100°F (56°C).

In all cases, the tCL alarm occurs during heating when little temperature rise is detected. This can be the result of a component failure at elevated temperatures; most likely a failed heating elements or a control relay. Another possible problem is with the thermocouple sensor signal; if the thermocouple probe is not properly positioned in the firing chamber or if the wiring from the sensor has short-circuited the controller will not detect actual temperature changes in the firing chamber.

ETH - This alarm indicates that the Electronics temperature is too hot for controller operation. The controller temperature must be below 176°F (80°C) to prevent damage to the sensitive electronic. The ETH alarm cannot be cleared unless the board temperature has cooled. If the ETH occurs frequently, check the kiln for heat loss near the controller. Proper venting and heat-shielding should be inspected.

FE # - Fatal software Errors, FE Alarms indicate a hardware failure of software problem with the controller. These alarms will disable the normal controller operation and require corrective action. If a Fatal Error occurs during an active firing, the firing is terminated. These alarms include;

- FE 1 - Failed to read or write to memory device
- FE 2 - Failed memory test during power on
- FE 3 - Corrupt data found in memory
- FE 4 - Errors detecting thermocouple input signal *
- FE 5 - Software Execution failed

Turn the controller off and back on to try and clear the alarm. If the alarm reoccurs immediately or frequently, the controller may require service or replacement.

* FE 4 alarms can often be solved by correcting problems with the system thermocouple. Loose connections or faulty thermocouple wiring or a faulty thermocouple can result in this alarm.

Firing Schedules/Programs

To select any of the available programs, first press the Program button when the display shows **IdLE**. The last used program will be the first choice on the controller display. If a different program is desired, press the Increase button to select another program. Then press the Program button again when the displays shows the program code you want. The available selections will be;

→Std → P F → P3 F → P3 S → G22S → USER

Flow Diagram for Programming

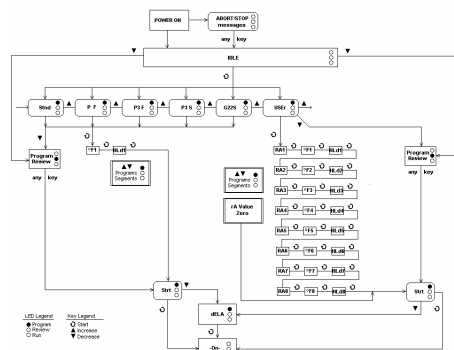

rA3 = 0297 °F 3 = 1675 HLD3 = 00.00
 rA4 = 0108 °F 4 = 1828 HLD4 = 00.00
 rA5 = 0000

Standard PMC Program Example

Below is a standard 1 step firing schedule for Standard PMC using the preset PMC Program.

Step 1. Heat as fast as possible to a final temperature of 1650°F, Hold at 1650°F for 2 hours and 15 minutes.

To program this schedule from **IdLE** mode;

- Press (Program) button. The controller will display the last active program that was used. (Stnd , P F, P3 F, P3 S, G22S or USEr)
- Press (Program) button again if Stnd is displayed or press (Increase) button until the display shows Stnd then press (Program) button again.
- Verify the °F 1 temperature is set to 1650°F, If not, Press the (Increase) or (Decrease) button to adjust the Temperature. Then press (Program) button again.
- Verify the HLD1 hold time is set to 02:15, If not, Press the (Increase) or (Decrease) button to adjust the hold time. Then press (Program) button again.
- The display shows **Strt** after the hold time entry above.
- Press (Program) button one last time to start the firing. Display will show -On-

Ceramic Glaze (Cone06) User Program Example

Below is the same firing schedule for Cone06 as a Ramp/Hold program.

- Heat from starting temperature to 1031°F at 360°F/Hour, with no Hold time at 1031°F
- Heat from 1031°F to 1103°F at 180°F/Hour, with no Hold time at 1103°F
- Heat from 1103°F to 1675°F at 297°F/Hour, with no Hold time at 1675°F
- Heat from 1675°F to 1828°F at 108°F/Hour, with no Hold time at 1828°F, then Shut-off

To program this schedule from **IdLE** mode;

- Press (Program) button. The controller will display the last active program that was used. (Stnd , P F, P3 F, P3 S, G22S or USEr)
- Press (Program) button again if the desired USEr is displayed or press (Increase) button until the display shows the desired USEr. Then press (Program) button again.
- Program the steps below and press (Program) button after each segment.

rA1 = 0360 °F 1 = 1031 HLD1 = 00.00
 rA2 = 0180 °F 2 = 1103 HLD2 = 00.00

- The display shows **Strt** after the final entry above.
- Press (Program) button one last time to start the firing. Display will show -On-

Glass Fusing/Slumping User Program Example

Below is a typical 4 step firing schedule for Glass Slumping or Fusing.

- Heat from starting temperature to 750°F at 250°F/Hour, with no Hold time at 750°F
- Heat from 750°F to 1425°F at 900°F/Hour, Hold at 1425°F for 30 minutes
- Cool as fast as possible from 1425°F to 1050°F, with no Hold time at 1050°F
- Cool from 1050°F to 750°F at 150°F/Hour, then Shut-off

To program this schedule from **IdLE** mode;

- Press (Program) button. The controller will display the last active program that was used. (Stnd , P F, P3 F, P3 S, G22S or USEr)
- Press (Program) button again if the desired USEr is displayed or press (Increase) button until the display shows the desired USEr. Then press (Program) button again.
- Program the steps below and press (Program) button after each segment.

rA1 = 0250 °F 1 = 0750 HLD1 = 00.00
 rA2 = 0900 °F 2 = 1425 HLD2 = 00.30
 rA3 = FULL °F 3 = 1050 HLD3 = 00.00
 rA4 = 0150 °F 4 = 0750 HLD4 = 00.00
 rA5 = 0000

- The display shows **Strt** after the final entry above.
- Press (Program) button one last time to start the firing. Display will show -On-

Heat Treating User Program Example

Below is a typical 3 step firing schedule for Heat Treating Steel.

- Heat as fast as possible from starting temperature to 1800°F, Hold at 1800°F for 20 minutes
- Cool as fast as possible from 1800°F to 400°F, with no hold time at 400°F
- Heat as fast as possible from 400°F to 500°F, Hold at 500°F for 5 hours, then Shut-off

To program this schedule from **IdLE** mode;

- Press (Program) button. The controller will display the last active program that was used. (Stnd , P F, P3 F, P3 S, G22S or USEr)

- Press (Program) button again if the desired USEr program is displayed or press (Increase) button until the display shows the desired USEr. Then press (Program) button again.
- Program the steps below and press (Program) button after each segment.

rA1 = FULL °F 1 = 1800 HLD1 = 00.20
 rA2 = FULL °F 2 = 0400 HLD2 = 00.00
 rA3 = FULL °F 3 = 0500 HLD3 = 05.00
 rA4 = 0000

- The display shows **Strt** after the final entry above.
- Press (Program) button one last time to start the firing. Display will show -On-

Wiring Diagram

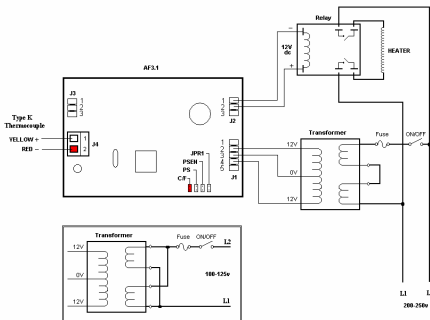

Limited Warranty

This limited warranty is given only to the immediate purchaser ("Buyer") of the Autofire® Express kiln controller. This limited warranty is not transferable. The Edward Orton Jr. Ceramic Foundation ("Orton") warrants the controller motherboard installed on the Autofire® Express ("Warranted Components") to be in good working order under normal operating conditions for a period of one (1) year from the date of purchase. Should the Warranted Components fail to be in good working order at any time during the stated one (1) year period, Orton will, at its option, repair or replace the Warranted Components as set forth below. The liability of Orton is limited to replacement and/or repair at its factory of the Warranted Components that does not remain in good working order. Repair parts or replacement products will be furnished on an exchange basis and will be either reconditioned or new. All replaced parts or products become the property of Orton. Following receipt of notice from Buyer of a valid warranty claim and the Autofire® Express containing the Warranted Components, Orton will perform its obligations under this limited warranty within 10 business days.

Limited warranty service may be obtained by delivering the Autofire® Express during the warranty period to your Orton Supplier or to The Edward Orton Jr. Ceramic Foundation, 6991 Old 3C Highway, Westerville, Ohio 43082 and providing written proof of purchase and a description of the defect or problem. Buyer must insure the shipment or assume the risk of loss or damage in transit, prepay shipping charges to the service location, and use the original shipping container or equivalent. Buyer will be responsible for shipping and handling charges in excess of US \$50.00 incurred by Orton in returning the Autofire® Express to the Buyer after completion of limited warranty service.

This warranty does not apply to any damage to the Autofire® Express resulting from:

- Operation beyond electrical rating.
- External sources including, but not limited to, chemicals, heat abuse and improper care.
- Improper or inadequate maintenance by Buyer.
- Parts or equipment not supplied by Orton.
- Unauthorized modification or misuse.
- Operation outside environmental specifications.
- Improper installation.
- Over firing (melting of materials being fired) regardless of the cause of the over firing.

Warranted Components returned for service where no warranted defect is found will be subject to service, and shipping and handling fees.

If the Warranted Components are not in good working order as warranted above, Buyer's sole remedy shall be repair or replacement of the Warranted Components as provided above.

TO THE EXTENT PERMITTED BY LAW, ALL EXPRESS AND IMPLIED WARRANTIES FOR THE WARRANTED COMPONENTS INCLUDING THE WARRANTIES OF MERCHANTABILITY AND FITNESS FOR A PARTICULAR PURPOSE ARE LIMITED TO THE ONE YEAR WARRANTY PERIOD COMMENCING ON THE DATE OF PURCHASE, AND NO OTHER WARRANTY WHETHER EXPRESS OR IMPLIED WILL APPLY TO THIS PERIOD. TO THE EXTENT PERMITTED BY LAW, ORTON'S REMEDY AND BUYER'S SOLE REMEDY IS LIMITED SOLELY AND EXCLUSIVELY TO REPAIR OR REPLACEMENT AS SET FORTH HEREIN. ORTON SHALL NOT BE LIABLE FOR, AND BUYER'S REMEDY SHALL NOT INCLUDE ANY INCIDENTAL, CONSEQUENTIAL OR OTHER DAMAGES OF ANY KIND WHATSOEVER, WHETHER A CLAIM IS BASED UPON THEORY OF CONTRACT, NEGLIGENCE OR TORT.

Buyer shall determine suitability of the Autofire[®]Express for the intended use and assume all risk and liability therewith. Some states do not allow this exclusion or limitation of incidental or consequential damages, so the above limitation or exclusion may not apply to you. This warranty gives you specific legal rights, and you may also have other rights which vary from State to State.

The above limitation does not apply in the event that any Warranted Components are determined by a court of competent jurisdiction to be defective and to have directly caused bodily injury, death or property damage; provided that in no event shall Orton's liability exceed the greater of \$1,000.00 or the purchase price of the specific Autofire[®]Express that caused such damage.

Service may also be obtained on Warranted Components no longer under warranty by returning the Autofire[®]Express prepaid to Orton with a description of the problem and Buyer's name and contact information. Buyer will be contacted with an estimate of services charges before any work is performed.

Customer Satisfaction Policy

If for any reason you are not completely satisfied with the performance of the Orton Autofire[®]Express or the conditions of this warranty, return the Autofire[®]Express in good working condition, transportation and insurance prepaid, within 30 days of purchase date to your supplier or The Edward Orton Jr. Ceramic Foundation, 6991 Old 3C Highway, Westerville, Ohio 43082 and your purchase price will be refunded. Prior to returning your Autofire[®]Express contact Orton for an authorization number and include with your shipment. For controllers ordered in error, a restocking charge will apply.